

Dehumidifier RECUSORB RZ-071/081/101/102

Dehumidifying capacity
at 20°C / 60%RH

14 - 50 kg/h

Dry air flow

2 500 - 7 000 m³/h



RZ-101

RZ-081

- Washable rotor
- No desiccant carry-over
- Ideal for storage applications
- Built-in heat recovery
- Low dry air temperature
- Long lifetime

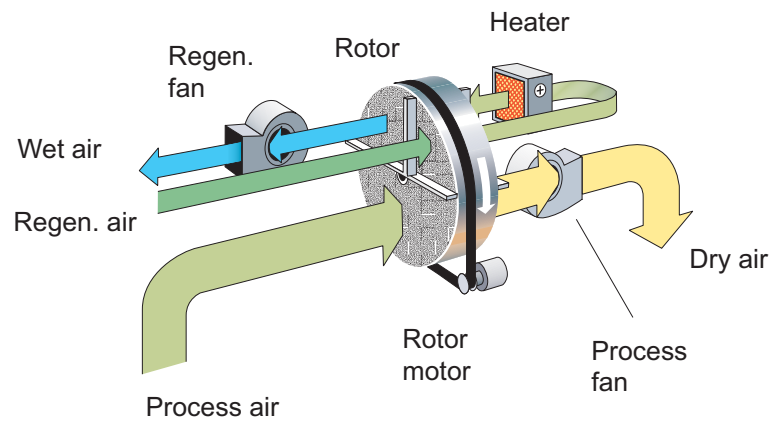

Contains the SSCR rotor -
one step ahead in
adsorption technology

The high number of channels
means that moisture is adsorbed
with extra efficiency!

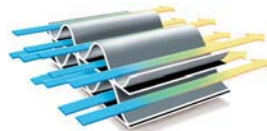

Dehumidifier model	RZ-071	RZ-081	RZ-101	RZ-102
Nominal capacity *	14 kg/h	19 kg/h	30 kg/h	50 kg/h
Dry air flow ***	2 500 m ³ /h	2 800 m ³ /h	4 500 m ³ /h	7 000 m ³ /h
Static pressure at disposal	400 Pa	400 Pa	400 Pa	400 Pa
Wet air flow **	780 m ³ /h	1 000 m ³ /h	1 800 m ³ /h	2 500 m ³ /h
Static pressure at disposal	200 Pa	200 Pa	200 Pa	200 Pa
Heater power	16 kW	24 kW	40 kW	63 kW
Maximum electric consumption	19 kW	27 kW	44 kW	70 kW
Supply fuse 3x 230/400V 50Hz	63 / 35 A	80 / 50 A	125 / 80 A	250 / 125 A
Weight	280 kg	294 kg	380 kg	503 kg

* Valid for inlet conditions 20°C/ 60%RH. For other inlet conditions the capacity can be calculated by using the correction factor from the diagram shown below.

** Volume flow for density 1,20 kg/m³.

*** Available with electric heater, steam heater or gas heater.

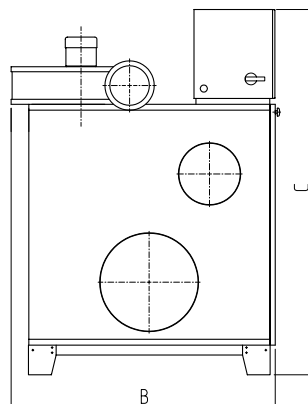
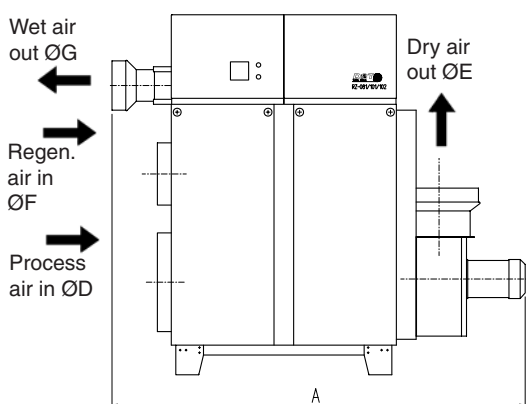
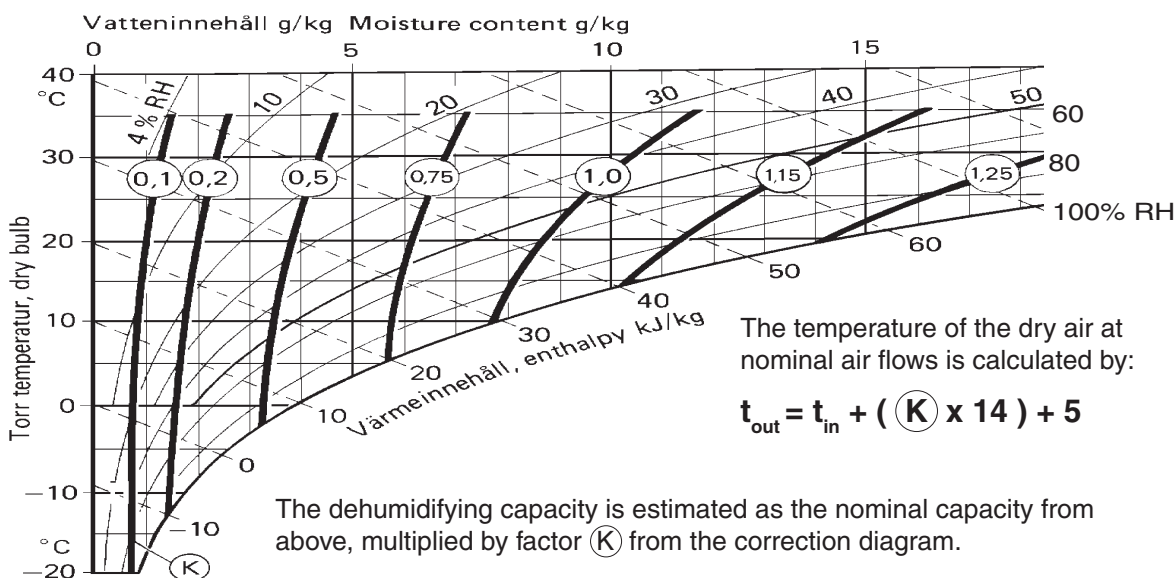

Subject to change without notice.

Please note:
Preliminary dimensions for RZ-071

Dimensions for RZ units [mm]				
RZ-	071	081	101	102
A	1 800	1 800	2 100	2 200
B	950	950	1 340	1 250
C	1 500	1 550	1 850	1 940
D	400	400	500	630
E	250	250	400	500
F	200	200	315	400
G	160	160	250	315

Seibu Giken DST AB
Avestag, 33, S-163 53 Spånga, Sweden
www.dst-sg.com E-mail: info@dst-sg.com
tel: +46-8 4457720; fax: +46-8 4457739

Representative: